

CP-UNP-F3021L20-DAP

2MP WDR 30x IR Network PTZ Camera - 200 Mtr.

- 1/2.8" 2MP PS CMOS Image sensor (0.9071cm)
- Max. 50/60fps@1080P
- Powerful 30x Optical zoom and 16x Digital zoom
- WDR(120dB), 2D/3D DNR, Day/Night (ICR), ROI, EIS, Defog, AGC, BLC, HLC
- Support Starlight Technology
- Up to 300 presets, auto scan, 8 tour, 5 pattern, auto pan
- IR Range of 200 Mtr.
- Max 300° /s pan speed, 360° endless pan rotation
- Built-in 7/2 alarm in/out, IP67, IK10, Support PoE+
- Mobile Software: iCMOB, gCMOB
- CMS Software: KVMS Pro



System Overview

Using the advanced algorithms of the twenty-first century this Series by CP Plus has been boosted with the starlight technology which is widely used for getting sharper and clearer images with the help of the unprecedented starlight sensitivity that improves night vision for the camera in low-light conditions. On top of that, the Pro Series also consists of the highly efficient H.265+ compression technology.

Functions

Starlight Technology

This camera is widely used to provide sharper and clearer picture quality with the help of its exceptional starlight sensitivity as the camera improves night vision in low light conditions. This technology is useful in conditions with extremely low light as the starlight technology turns almost completely dark images into those of clear colors.



CP-UNP-F3021L20-DAP

2MP WDR 30x IR Network PTZ Camera - 200 Mtr.

Functions

Wide dynamic range (WDR)

When a scene is partly dark and partly bright, that is the dynamic range that distorts images due to this difference in the lighting. WDR technology provides you balanced lighting for a clear and vivid image throughout the day. WDR technology can be installed at entry/exit points of any building structure, jewellery shops, outdoor location among so many other places.

Auto-tracking

This technology enables you to control the pan/tilt/zoom actions in your camera in varying proportions to let you automatically and continuously track an object in the scener that is in motion or is moving. This function comes with the option of automatic or manual tracking depending on the condition to make it more efficient. This is done on the basis of predefined rules. Once such a rule is triggered, the camera can take over on its own and can track the defined target automatically.

Instastream

This camera has been designed with the latest and most efficient innovation among the standard video compression designs. Smart encoding algorithms developed by CP PLUS help in saving up to 70% more bandwidth than H.265 along with making it more beneficial for minimizing bandwidth and storage costs. It enhances video coding efficiency while providing high resolution and the rate of frame in the video using Intelligent Region Perception to detect motion in each frame.

About CP PLUS

The brand that is on its way to lead the world when it comes to the security and surveillance industry, CP PLUS, keeps bombarding the market with the most reliable range of products that have been designed carefully and methodically to automate the whole surveillance and security process, no matter how big your premises are.

It was the initiative to help the public in the area where they are the most vulnerable and to empower the sense of safety in our hearts that had conceptualized CP PLUS. And embarking on its mission to make the world a safer and more secure place has taken the brand's journey to unprecedented levels even when compared to international competitors.

True Day/Night (ICR)

When the scene is too dark, the image is captured by illuminating an infrared light through the camera onto the scene that greatly helps with making the scene visible for the lens. It delivers color images during the day and automatically switches to the monochrome feature as the scene darkens.

gCMOB/ iCMOB

Designed to allow users to access and control live streaming from CP PLUS IP Cameras, DVRs/ NVRs and Video Door Phones, the CP PLUS gCMOB/ iCMOB application offers a host of features such as Easy GUI, up to 16 live viewing split-ups; InstaOn cloud support; Playback; digital zoom ins; two-way talk, and more.

KVMS Pro

The KVMS Pro is a hybrid security management software that allows the management of various surveillance devices such as cameras, DVRs/ NVRs, encoders/ decoders, etc. It is released with the surveillance hardware and exclusively supports CP PLUS devices.



CP-UNP-F3021L20-DAP

2MP WDR 30x IR Network PTZ Camera - 200 Mtr.

Feature	Specification
Image Sensor	1/2.8" CMOS Image Sensor (0.9071cm)
Effective Pixels	1920(H) x 1080(V), 2 Megapixels
Video Output	1 port (BNC, 1.0V[p-p], 75Ω)
S/N Ratio	More than 55dB
Minimum Illumination	Color: 0.005Lux@F1.6; B/W: 0.0005Lux@F1.6; 0Lux@F1.6 (IR on)
Focal Length	4.5mm~135mm
White Balance	Auto, ATW, Indoor, Outdoor, Manual
Focus Control	Auto / Manual
Max. Aperture	F1.6 ~ F4.4
DORI Distance	1862m(Detect) 744m(Observe) 372m(Recognize) 186m(Identify)
Close Focus Distance	100mm~ 1000mm
Angle of View	H: 67.8° ~ 2.4°
Electronic Shutter	1/1s~1/30,000s
AGC control	Auto / Manual
Back Light Compensation	BLC / HLC / WDR(120dB)
Optical Zoom	30x
Digital Zoom	16x
Pan Travel	0°~360° endless, Pan Speed: 0.1° ~ 200°/sec
Tilt Travel	-20° ~ 90° auto flip 180°, Tilt Speed: 0.1° ~120°/sec
Manual Speed	Pan: 0.1° ~200° /s; Tilt: 0.1° ~120° /s
Presets	300
Preset Speed	Pan: 300° /s; Tilt: 200° /s
Privacy Masking	Up to 24 areas
Special Features	IR Range upto 200m, Up to 300 Presets, 5 Pattern, 8 Tour, Auto Pan , Auto Scan
Power up Action	Auto restore to previous PTZ and lens status after power failure
Idle Motion	Activate Preset/ Scan/ Tour/ Pattern if there is no command in the specified period
Day/Night: IR Cut Filter	Auto (ICR) / Color / B/W

Feature	Specification
Video Compression	H.265/H.264+/H.264/MJPEG (Sub Stream)
Encode Strategy	Instastream
Stream	Quad Stream
Video Streaming	Main stream: 1080P/1.3MP/720P(1~25fps), Sub stream1: D1/CIF(1 ~ 25fps), Sub stream2: 1080P/1.3MP/720P/D1/CIF (1~25fps); Sub Stream3: D1/CIF(1~25fps)
Audio Compression	G.711a/G.711Mu/AAC/G.722 / G.726/G.729/ MPEG2-L2
Motion Detection	Support
ROI	Support
Audio Streaming	1/1 channel In/Out
Auto Tracking	Support
IVS	Tripwire, Intrusion, Abandoned/Missing, Face Detection, Heat Map
Streaming Method	Unicast / Multicast
Event Trigger	Motion detection, Video tampering , Scene changing, Network disconnection, IP address conflict, Illegal Access, Storage anomaly
Networking	RJ-45 (10Base-T/100Base-TX) , 1 RS485
Protocols	IPv4/IPv6, HTTP, HTTPS, SSL, TCP/IP, UDP, UPnP, ICMP,IGMP, SNMP, RTSP, RTP, SMTP, NTP, DHCP, DNS, PPPOE, DDNS, FTP, IP Filter, QoS, Bonjour,802.1x, ONVIF Profile S & G, API
Alarm	7/2 channel In/Out
Max Remote Users	20 users
Operating Temperature	-40°C ~ 70°C (-40°F ~ +158°F) / Less than 95% RH
Smart Phone	iPhone, iPad, Android Phone
Memory Slot	NAS (Network Attached Storage), Local PC for instant recording, Micro SD card 256GB
Weather Proof Standard	IP67 & IK10
Dimension	φ209mm x 337.4mm
Weight	5.8 kg
Casing	Metal
Power Source	AC24V/3A(±25%), PoE+(802.3at)
Power Consumption	17W, 25W(IR On, Heater On)

Dimensions (mm/inch)

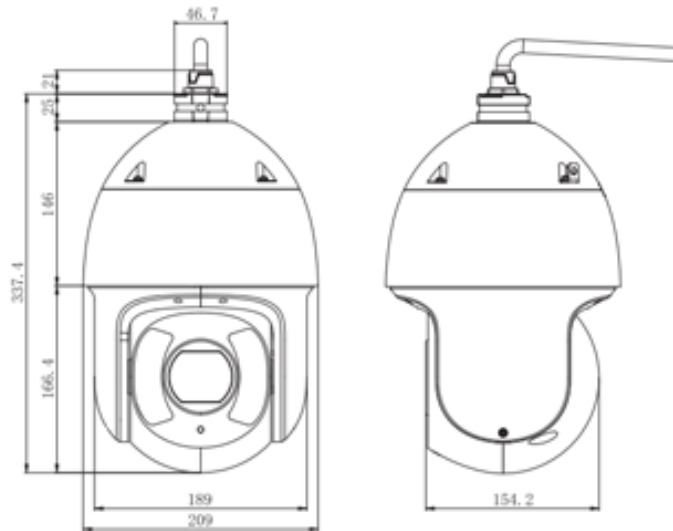

Accessories : Optional



CP-UA-B3P
Pole Mount

Company Name:

CP PLUS (Aditya Infotech Ltd.)
F-28 Okhla Industrial Area, Phase 1,
New Delhi 110020, INDIA

Contact Mail ID :- customercare@cpplusworld.com